

MITSUBISHI SEWING MACHINE PARTS CATALOG

Model..... {
 DN260
 DN262
 DN265
 DN267

INDEX

1. DN260, 262, 265, 267形主要部品表.....	DN260, 262, 265, 267 Model main parts list	1
2. 本体部分.....	Arm bed and its accessories	2
3. 上軸部分.....	Upper shaft mechanism	6
4. 押工機構部分.....	Presser foot mechanism	8
5. 天ビン部分.....	Thread take-up mechanism.....	10
6. 下軸部分.....	Lower shaft mechanism	12
7. 送り軸部分.....	Lower feed mechanism	14
8. カマ機構.....	Hook mechanism	16
9. 給油機構.....	Lubrication mechanism.....	18
10. 給油機構(DN265, 267)	Lubrication mechanism(for DN265, 267)	20
11. 返し縫い機構(DN265, 267)	Reverse lever mechanism(for DN265, 267)	22
12. ゲージ部品.....	Gauge parts	24
13. 付属品(付属品箱)	Accessories(Accessory box)	25
14. 付属品.....	Accessories	26

 **MITSUBISHI ELECTRIC CORPORATION**

197601

機 構 図 TOTAL ASSY,

ModelDN265

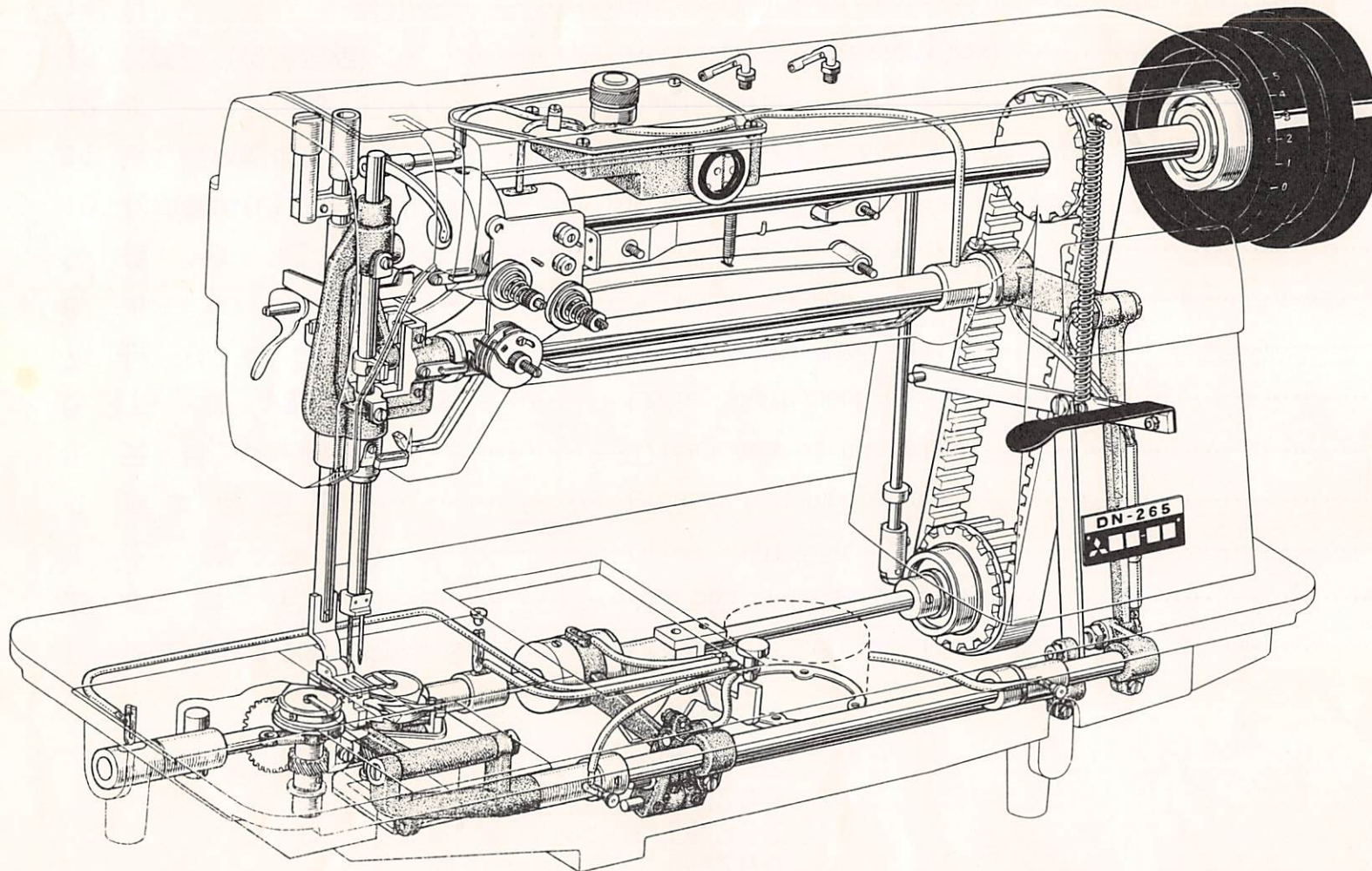

DN260.262.265.267形主要部品表 Main parts list

Fig. No.	サービス部品コード Part No.	資材コード Code No.	品 名	Name of part	個 / 台 Amt. req				備 考 Remarks
					DN260	DN262	DN265	DN267	
1		W225177G01	アームベット (組)	Arm bed Assy,	①				
		W225177G02	アームベット (組)	Arm bed Assy,		①			
		W220699G01	アームベット (組)	Arm bed Assy,			①		
		W220699G02	アームベット (組)	Arm bed Assy,				①	
5		W461772H01	形 名 板	Model plate	①				
		W470956H01	形 名 板	Model plate		①			
		W470957H01	形 名 板	Model plate			①		
		W470958H01	形 名 板	Model plate				①	
6		W220608H01	面 板	Face plate		①		①	
		W219157H01	面 板	Face plate	①		①		
65		W462915H01	ク ラ ン ク	Needle bar crank		①		①	
		W445865H01	ク ラ ン ク	Needle bar crank	①		①		
103		W328876H01	押 エ	Presser foot		①		①	
		W446006H01	押 エ	Presser foot	①		①		
116		W462828H01	天 び ん	Thraed take-up lever		①		①	
		W445882H01	天 び ん	Thread take-up lever	①		①		
207		W467824H01	送 り	Feed dog		①		①	
		W319988H01	送 り	Feed dog	①		①		
212		W326230H01	カ マ	Rotating hook Assy,		②		②	
		W319995H01	カ マ	Rotating hook Assy,	②		②		
214		W459390H01	オ ー プ ナ ー 支 エ	Bobbin case opener lever		②		②	
		W445902H01	オ ー プ ナ ー 支 エ	Bobbin case opener lever	②		②		
222		W462940H01	カマ軸メタル (上)	Hook driving shaft bushing (upper)		②		②	
		W445898H01	カマ軸メタル (上)	Hook driving shaft bushing (upper)	②		②		
223		W220606H01	カ マ 台 (右)	Hook base (right)		①		①	
		W220612H01	カ マ 台 (右)	Hook base (right)	①		①		
238		W220626H01	カ マ 台 (左)	Hook base (left)		①		①	
		W220611H01	カ マ 台 (左)	Hook base (left)	①		①		
802		W462929H01	ボ ビ ン	Bobbin		④		④	
		W445964H01	ボ ビ ン	Bobbin	④		④		

本体部分 ARM BED

DN-260
DN-262
DN-265
DN-267

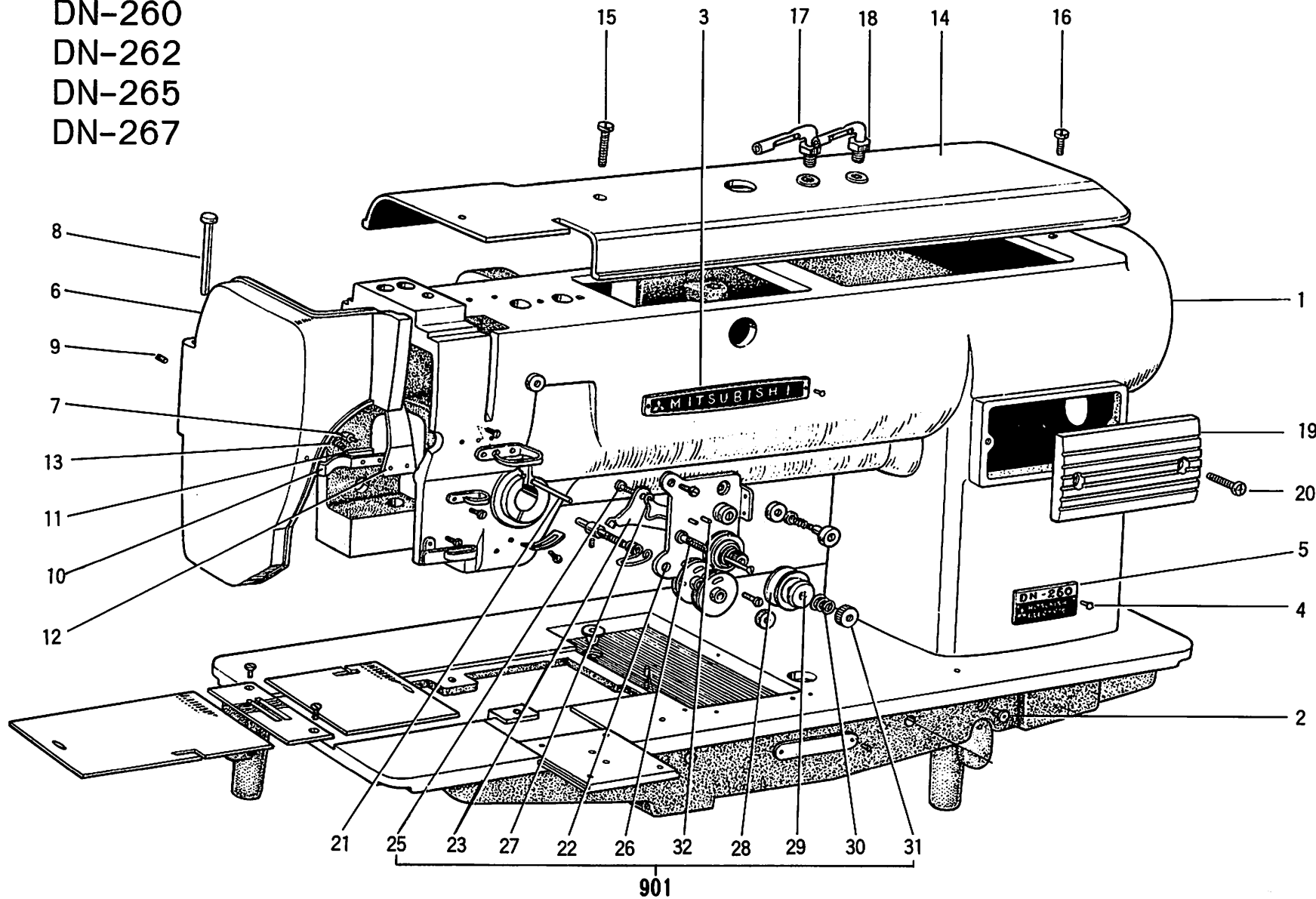

DN-260・262・265・267形 本体部分 ARM BED

Fig. No.	サービス部品コード Part No.	資材コード Code No.	品 名	Name of Part	個 / 台 Amt. req				備 考 Remarks
					DN260	DN262	DN265	DN267	
1		W225177G01	アームベット(組)	Arm and bed	①				
		W225177G02	アームベット(組)	Arm and bed		①			
		W220699G01	アームベット(組)	Arm and bed			①		
		W220699G02	アームベット(組)	Arm and bed				①	
2		W462905H01	フ タ	Cover	③	③	③	③	
3		W450620H01	シャメイバン	Name plate	①	①	①	①	
4		S573141H03	ネジリベット2×5	Screw for name plate	⑥	⑥	⑥	⑥	
5		W461772H01	カタメイバン	Model plate	①				
		W470956H01	カタメイバン	Model plate		①			
		W470957H01	カタメイバン	Model plate			①		
		W470958H01	カタメイバン	Model plate				①	
6		W219157H01	メンイタ	Face plate	①		①		
		W220608H01	メンイタ	Face plate		①		①	
7		W500989H01	ピン	Pin for face plate	①	①	①	①	
8		W445860H01	ダンツキジク(面板)	Face plate holder stud	①	①	①	①	
9		W500588H01	トメネジ 9/64(40)×3.2	Face plate set screw	①	①	①	①	
10		W445862H01	イタバネ(面板)	Face plate set spring	①	①	①	①	
11		W445874H01	スベーサ	Washer	①	①	①	①	
12		W445863H01	アブラウケ	Oil rejector	①	①	①	①	
13		W500993H01	マルサラネジ 3/16(28)×11	Screw	②	②	②	②	
14		W219155H01	トップカバー	Top cover	①	①	①	①	
15		W500261H01	ヒラネジ 9/64(40)×14	Screw for top cover	①	①	①	①	
16		W500262H01	ヒラネジ 9/64(40)×23	Screw for top cover	①	①	①	①	
17		W445861H01	イトアンナイ(トップカバー)	Thread guide for top cover	②	②	②	②	
18		W500001H01	ナット 3/16(28)	Thread guide nut	②	②	②	②	
19		W461026H01	フ タ(前蓋)	Front cover	①	①	①	①	
20		W466810H01	ブラマイネジ 11/64(40)×9	Front cover screw	②	②	②	②	
21		W501025H01	イトユルメピン(大)	Thread releasing pin(large)	①	①	①	①	
22		W450010H01	トリツケイタ	Thread regulator plate	①	①	①	①	
23		W450020H01	イトユルメ	Thread releasing plate	②	②	②	②	
25		W501026H01	ヒラネジダンツキ 9/64(40)	Screw	②	②	②	②	
26		W445932H01	チョウシボウ	Tension screw cover	①	①	①	①	
27		W502148H01	センサイクバネ(戻しバネ)	Reverse spring	①	①	①	①	
28		W445933H01	チョウシザラ	Tension disc	④	④	④	④	
29		W445934H01	チョウシザラオサエ	Disc Presser	②	②	②	②	
30		W461785H01	エンスイバネ(3)	Tension spring(3)	②	②	②	②	
31		W502940H01	ツマミナット	Tension nut	③	③	③	③	
32		W502063H01	ピン	Thread regulator plate pin	④	④	④	④	
901		W225101G01	チョウセツキクミタテ(上糸)	Thread tension regulator Assy,	①	①	①	①	

本体部分 ARM BED

DN-260
DN-262
DN-265
DN-266

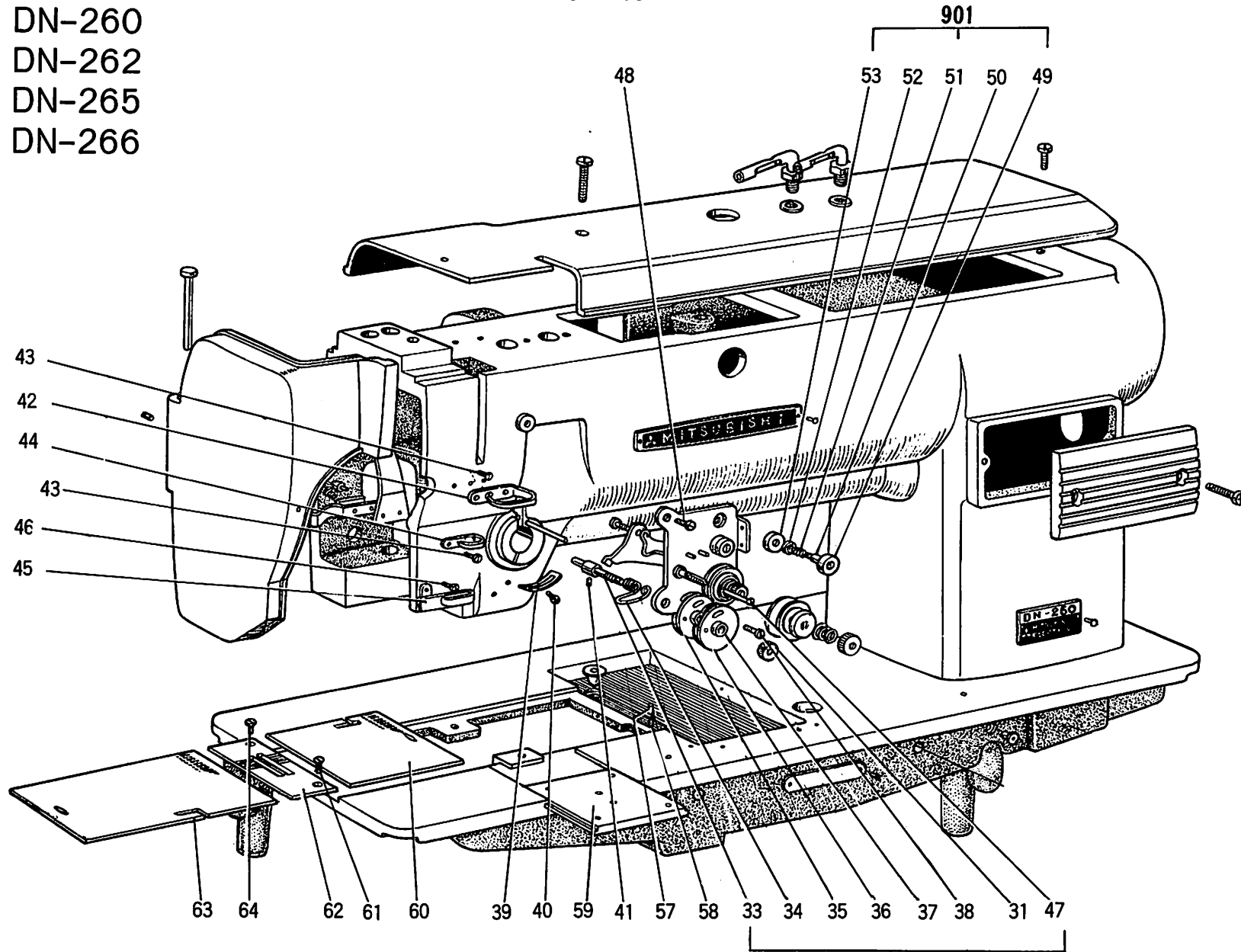

DN-260・262・265・267形 本体部分 ARM BED

Fig. No.	サービス部品コード Part No.	資材コード Code No.	品 名	Name of Part	個 / 台 Amt. req				備 考 Remarks
					DN260	DN262	DN265	DN267	
33		W450011H01	チ ョ ウ シ ジ ャ	Tension stud	①	①	①	①	
34		W450012H01	イ ト ト リ バ ネ	Take-up spring	①	①	①	①	
35		W445937H01	イ タ (糸案内車) (1)	Thread controller disc (1)	②	②	②	②	
36		W445938H01	イ タ (糸案内車) (2)	Thread controller disc (2)	②	②	②	②	
37		W445939H01	ブ ッ シ ャ (糸案内車ボス)	Thread controller stud	②	②	②	②	
38		W502062H01	マルヒラネジ 3/32(56)×12	Screw	①	①	①	①	
901		W225101G01	チョウセツキクミタテ (上糸)	Thread tension regulator Assy,	①	①	①	①	
39		W445942H01	ストッパー (糸取りバネ)	Tension spring stopper	①	①	①	①	
40		W500076H01	ヒ ラ ネ ジ 9/64(40)×5	Screw	①	①	①	①	
41		B509060H01	ト メ ネ ジ 15/64(28)×10	Screw	②	②	②	②	
42		W445857H01	イトアンナイ (アーム上)	Thread guide (upper)	①	①	①	①	
43		W500147H01	マルサラネジ 9/64(40)×6.5	Screw	②	②	②	②	
44		W445858H01	イトアンナイ (アーム中)	Thread guide (center)	①	①	①	①	
45		W446710H01	イトアンナイ (アーム下)	Thread guide (lower)	①	①	①	①	
46		W501523H01	ヒ ラ ネ ジ 9/64(40)×6.5	Screw	①	①	①	①	
47		W462824H01	ピ ン (糸ゆるめピン)	Thread releasing pin (small)	②	②	②	②	
48		W500294H01	ヒ ラ ネ ジ 11/64(40)×8	Screw	①	①	①	①	
49		W502211H01	キ ャ ッ プ	Thread controller cover	②	②	②	②	
50		W502210H01	マルヒラネジダンツキ 9/64(40)	Screw	②	②	②	②	
51		W502065H01	ツルマキバネ	Upper thread tension spring	②	②	②	②	
52		W502212H01	チ ョ シ ザ ラ	Thread guide disc	②	②	②	②	
53		W502213H01	アンナイダイ	Thread guide bracket	②	②	②	②	
57		W501034H01	ピ ン	Pin	①	①	①	①	
58		W501035H01	ツルマキバネ	Spring	①	①	①	①	
59		W319989H01	スベリイタ (前)	Slide plate (front)	①	①	①	①	
60		W445916H01	スベリイタ (右)	Slide plate (right)	①	①	①	①	
61		W502948H01	マルサラネジ 11/64(40)×5.7	Screw	①	①	①	①	
62		W467274H01	ハ リ イ タ	Needle plate	①	①	①	①	
63		W445915H01	スベリイタ (左)	Slide plate (left)	①	①	①	①	
64		W501004H01	マルヒラネジ 9/64(36)×6.5	Screw	①	①	①	①	

DN-260
DN-262
DN-265
DN-267

上軸部分 UPPER SHAFT MECHANISM

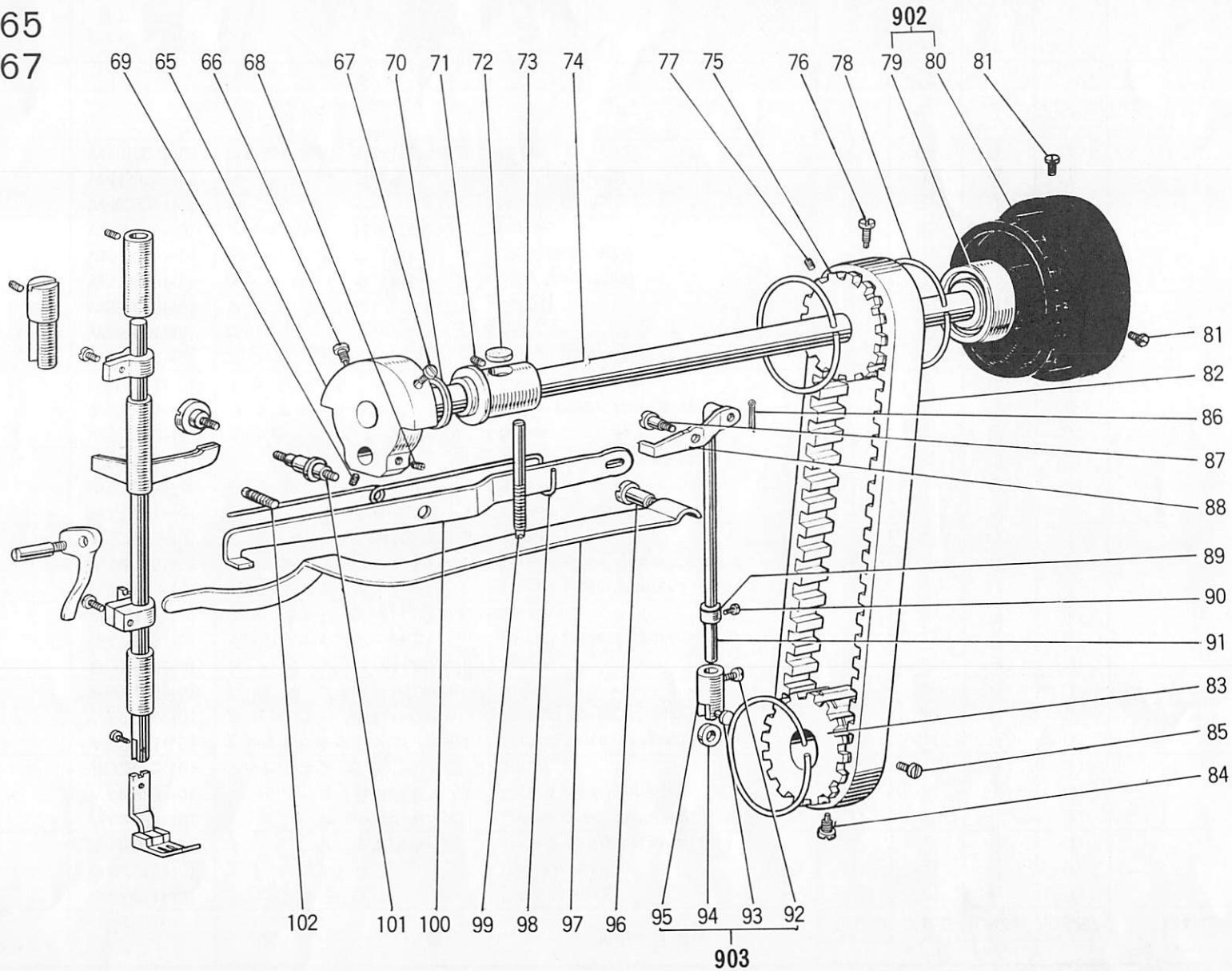

N-260·262·265·267形 上車部分 UPPER SHAFT MECH. JISM

Fig. No.	サービス部品コード Part No.	資材コード Code No.	品名	Name of Part	個/台 Amt. req				備考 Remarks
					DN260	DN262	DN265	DN267	
65		W445865H01	クランク	Needle bar crank	①		①		
		W462915H01	クランク	Needle bar crank		①		①	
66		B503851H01	ヒラネジボウサキ 9/32(28)	Position screw	①	①	①	①	
67		W500306H01	ヒラネジ 9/32(28)×13	Screw	①	①	①	①	
68		B504016H01	トメネジ 15/64(28)×4	Set screw	①	①	①	①	
69		W500486H01	トメネジ 15/64(28)×7	Set screw	①	①	①	①	
70		W445867H01	スリーブ	Ring	①	①	①	①	
71		W501017H01	トメネジ 1/4(24)×13	Screw for arm shaft bushing	①	①	①	①	
72		W501204H01	フェルト	Felt	①	①	①	①	
73		W445868H01	メタル(上軸)	Arm shaft bushing	①	①	①	①	
74		W319981H01	ウワジク	Arm shaft	①	①	①	①	
75		W447043H01	ハガタベルトグルマ(ベルト車 ^上)	Belt pulley(upper)	①	①	①	①	
76		B509256H01	マルヒラネジボウサキ 15/64(28)	Screw	①	①	①	①	
77		W500706H01	トメネジ 15/64(28)×9	Screw	①	①	①	①	
78		B411094H01	センサイクバネ	Spring flange	③	③	③	③	
79		W445869H01	ジクウケ	Ball bearing(upper shaft)	①	①	①	①	
80		W322720H01	ブリ-	Balance wheel	①	①	①	①	
81		W500509H01	ヒラネジ 15/64(28)×12	Set screw	②	②	②	②	
82		W326218H01	ハガタベルト	Timing belt	①	①	①	①	
83		W447044H01	ハガタベルトグルマ(ベルト車 ^下)	Belt pulley(lower)	①	①	①	①	
84		W501212H01	マルヒラネジボウサキ 15/64(28)	Screw	①	①	①	①	
85		B508963H01	ヒラネジ 15/64(28)×10	Screw	①	①	①	①	
902		W454814G01	ブリ-(組)	Balance wheel Assy.	①	①	①	①	
86		W500245H01	ワリピン	Cotter pin	①	①	①	①	
87		W501020H01	ヒラネジダンツキ 1/4(24)	Screw	①	①	①	①	
88		W445923H01	レバー(ひざ上げてこ(2))	Knee lifter lever (2)	①	①	①	①	
89		W445924H01	カラ-	Collar	①	①	①	①	
90		W500092H01	ヒラネジ 11/64(40)×5.5	Screw	①	①	①	①	
91		W319994H01	ソウサボウ(突上げ棒)	Lifting rod	①	①	①	①	
903			ローラーだき(組)	Rod roller bracket Assy.	①	①	①	①	
92		W500092H01	ヒラネジ 11/64(40)×5.5	Screw	①	①	①	①	
93		W501022H01	マルヒラネジダンツキ 9/64(40)	Screw	①	①	①	①	
94		W445940H01	ローラー	Rod roller	①	①	①	①	
95		W445925H01	ローラーダキ	Rod roller bracket	①	①	①	①	
96		W501006H01	マルヒラネジダンツキ 1/4(24)	Screw	①	①	①	①	
97		W319992H01	イタバネ(押え板ばね)	Presser spring	①	①	①	①	
98		W445922H01	ヒネリバネ	Lifting lever spring	①	①	①	①	
99		W445917H01	ピンネジ(押え調節ネジ)	Spring regulating screw	①	①	①	①	
100		W319993H01	レバー(ひざ上げてこ)	Lifting lever	①	①	①	①	
101		W446725H01	トクシュネジ	Lifting lever hinge screw	①	①	①	①	
102		W501019H01	ヒラネジ	Spring stop screw	①	①	①	①	

DN-260
DN-262
DN-265
DN-267

押工機構部分 PRESSER FOOT MECHANISM

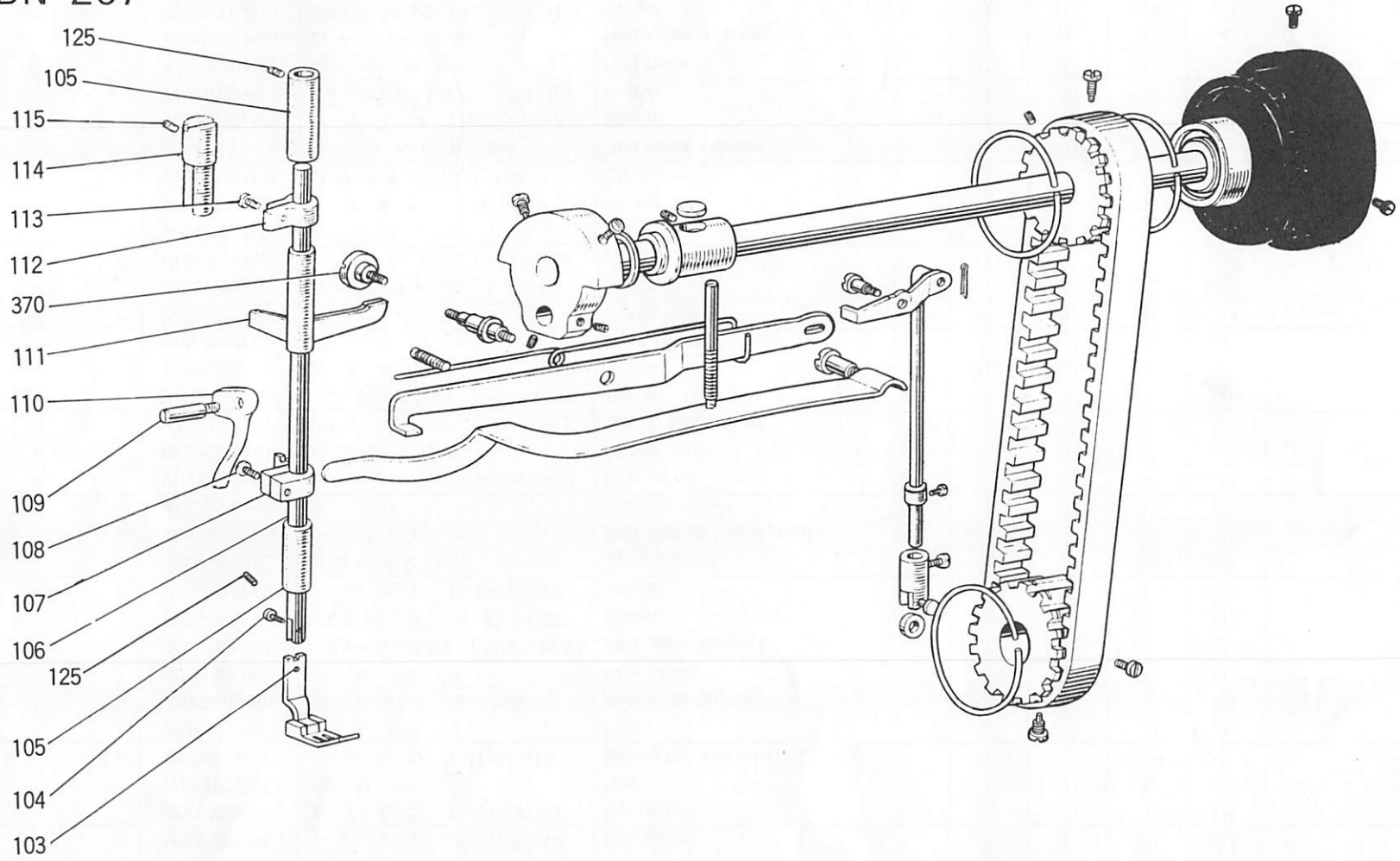

DN-260・262・265・267形 押工機構部分 PRESSER FOOT MECHANISM

Fig. No.	サービス部品コード Part No.	資材コード Code No.	品 名	Name of Part	個 / 台 Amt. req				備 考 Remarks
					DN260	DN262	DN265	DN267	
103		W446006H01 W328876H01	オ サ エ オ サ エ	Presser foot Presser foot	①		①		
104		W501007H01	ヒラネジダンツキ 1/8(44)	Screw	①	①	①	①	
105		W445929H01	メ タ ル (押え棒)	Presser bar bushing	②	②	②	②	
106		W445919H01	オ サ エ ボ ウ	Presser bar	①	①	①	①	
107		W445921H01	バ ネ ウ ケ	Spring bracket	①	①	①	①	
108		W500470H01	ヒラネジ 9/64(40)×8.5	Screw	①	①	①	①	
109		W501024H01	ピ ン ネ ジ	Hinge screw	①	①	①	①	
110		W459307H01	レ バ ー (押え上げ)	Presser bar lifter	①	①	①	①	
111		W319991H01	オサエボウアゲ	Releasing lever bracket	①	①	①	①	
112		W445920H01	オサエボウダキ	Presser bar guide lever	①	①	①	①	
113		B509268H01	マルヒラネジ 9/64(40)×10	Pinch screw	①	①	①	①	
114		W445918H01	アンナイガネ (押え棒案内)	Presser bar position guide	①	①	①	①	
115		W500478H01	トメネジ 1/4(24)×7	Set screw	①	①	①	①	
370		W501014H01	マルヒラネジダンツキ	Hinge screw	①	①	①	①	

DN-260 天びん部分 THREAD TAKE-UP MECHANISM
 DN-262
 DN-265
 DN-267

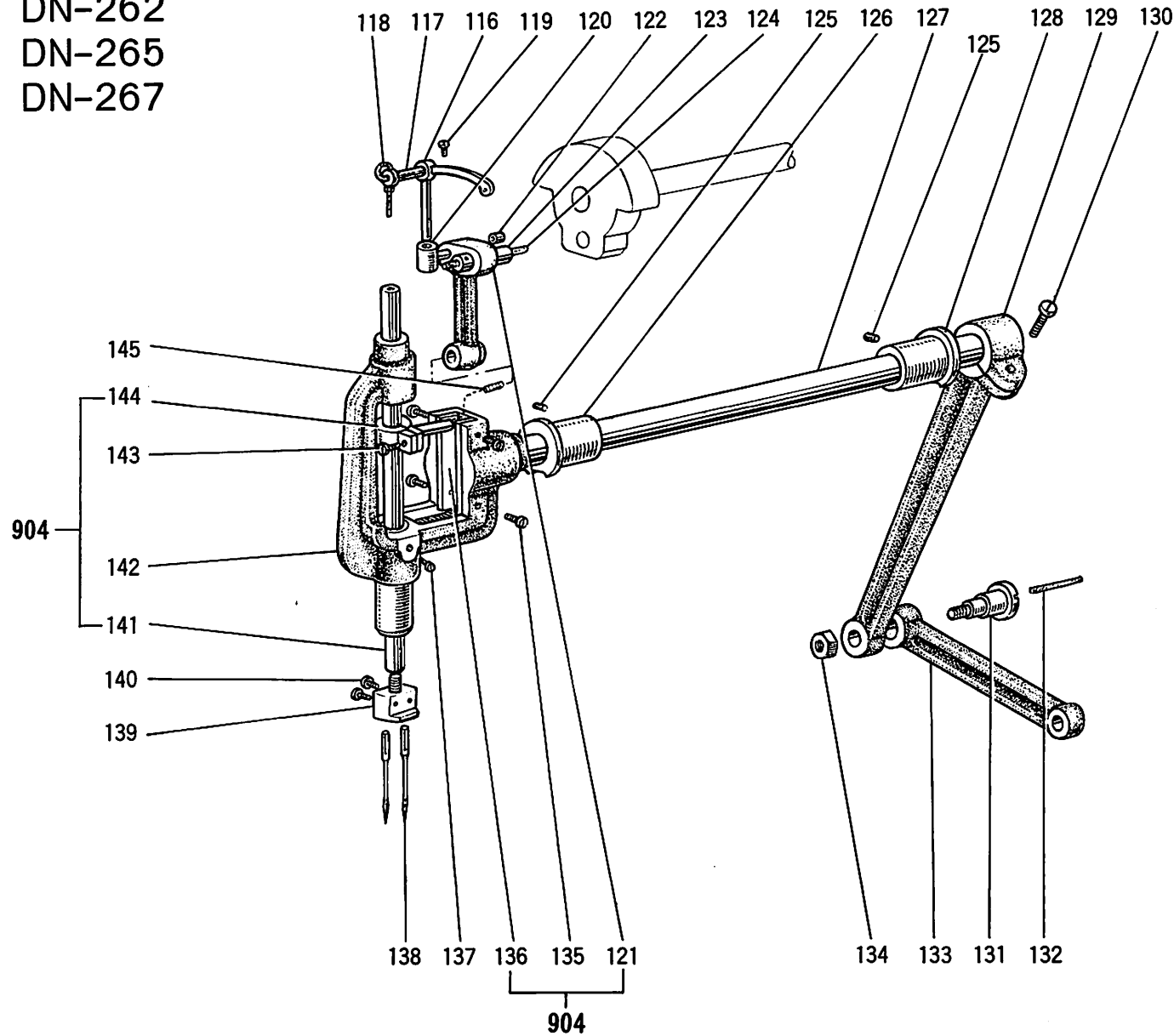

DN-260・262・265・267形 天びん部分 THREAD TAKE-UP MECHANISM

Fig. No.	サービス部品コード Part No.	資材コード Code No.	品 名	Name of Part	個 / 台 Amt. req				備 考 Remarks
					DN260	DN262	DN265	DN267	
116		W445882H01 W462828H01	テ ン ビ ン テ ン ビ ン	Thread take-up lever Thread take-up lever	①		①	①	
117		W445883H01	ダンツキジク (天秤支え軸)	Take-up lever support stud	①	①	①	①	
118		W444138H01	ヒ モ 2.5φ×240	Oil wick	①	①	①	①	
119		W500509H01	ヒ ラ ネ ジ 15/64 (28)×12	Screw	①	①	①	①	
120		W445881H01	スベリガネ (天秤滑り)	Take-up slide block	①	①	①	①	
121		W322764H01	レンセツカン (針棒クランクロッド)	Needle bar connection link	①	①	①	①	
122		W501275H01	セ ン (アルミ)	Plug (aluminium)	①	①	①	①	
123		W445866H01	ジ ク (クランクピン)	Crank pin	①	①	①	①	
124		W500801H01	フ ェ ル ト	Felt	①	①	①	①	
125		W500478H01	ト メ ネ ジ 1/4 (24)×7	Screw	⑥	⑥	⑥	⑥	
126		W462919H01	メ タ ル (針棒揺動軸左)	Needle bar rock frame rock shaft bushing (left)	①	①	①	①	
127		W445872H01	ジ ク (針棒揺動軸)	Needle bar rock frame rock shaft	①	①	①	①	
128		W445871H01	メ タ ル (針棒揺動軸右)	Needle bar rock frame rock shaft bushing (right)	①	①	①	①	
129		W319982H01	ウ デ (針棒揺動桿)	Needle bar rock frame rock shaft crank	①	①	①	①	
130		W501009H01	マルヒラネジ 1/4 (24)×16	Screw	②	②	③	③	
131		W501010H01	ヒラネジダンツキ 5/16 (24)	Hinge screw	①	①	①	①	
132		W462978H01	ヒ モ 2.5φ×78	Oil wick	①	①	①	①	
133		W445880H01	レンセツカン	Rock shaft crank link	①	①	①	①	
134		W501187H01	ナ ッ ト 5/16 (24)	Nut	①	①	①	①	
135		W501205H01	マルサラネジ 3/32 (56)×4	Screw	④	④	④	④	
136		W445873H01	ス ペ ー サ ー	Spacer	②	②	②	②	
137		B 508852H01	ヒ ラ ネ ジ 1/8 (44)×4.5	Screw	④	④	④	④	
138		S 970004H02 S 970004H06	ミシンハリ DP×5 #14 ミシンハリ DP×5 #21	Needle Needle	②		②	②	
139		W467851H01	ハ リ ダ キ	Needle clamp	①	①	①	①	
140		W500991H01	マルヒラネジ 9/64 (40)×3	Set screw	②	②	②	②	
141		W445878H01	ハ リ ボ ウ	Needle bar	①	①	①	①	
142		W324540H01	サ サ エ (針棒支え)	Needle bar rock frame	①	①	①	①	
143		W500470H01	ヒ ラ ネ ジ 9/64 (40)×8.5	Screw	①	①	①	①	
144		W445877H01	ハ リ ボ ウ ダ キ	Needle bar connecting stud	①	①	①	①	
145		W500499H01	フ ェ ル ト	Felt	①	①	①	①	
904			ハ リ ボ ウ サ サ エ (組)	Needle bar rock frame Assy.	①	①	①	①	

DN-260
DN-262
DN-265
DN-267

下軸部分 LOWER SHAFT MECHANISM

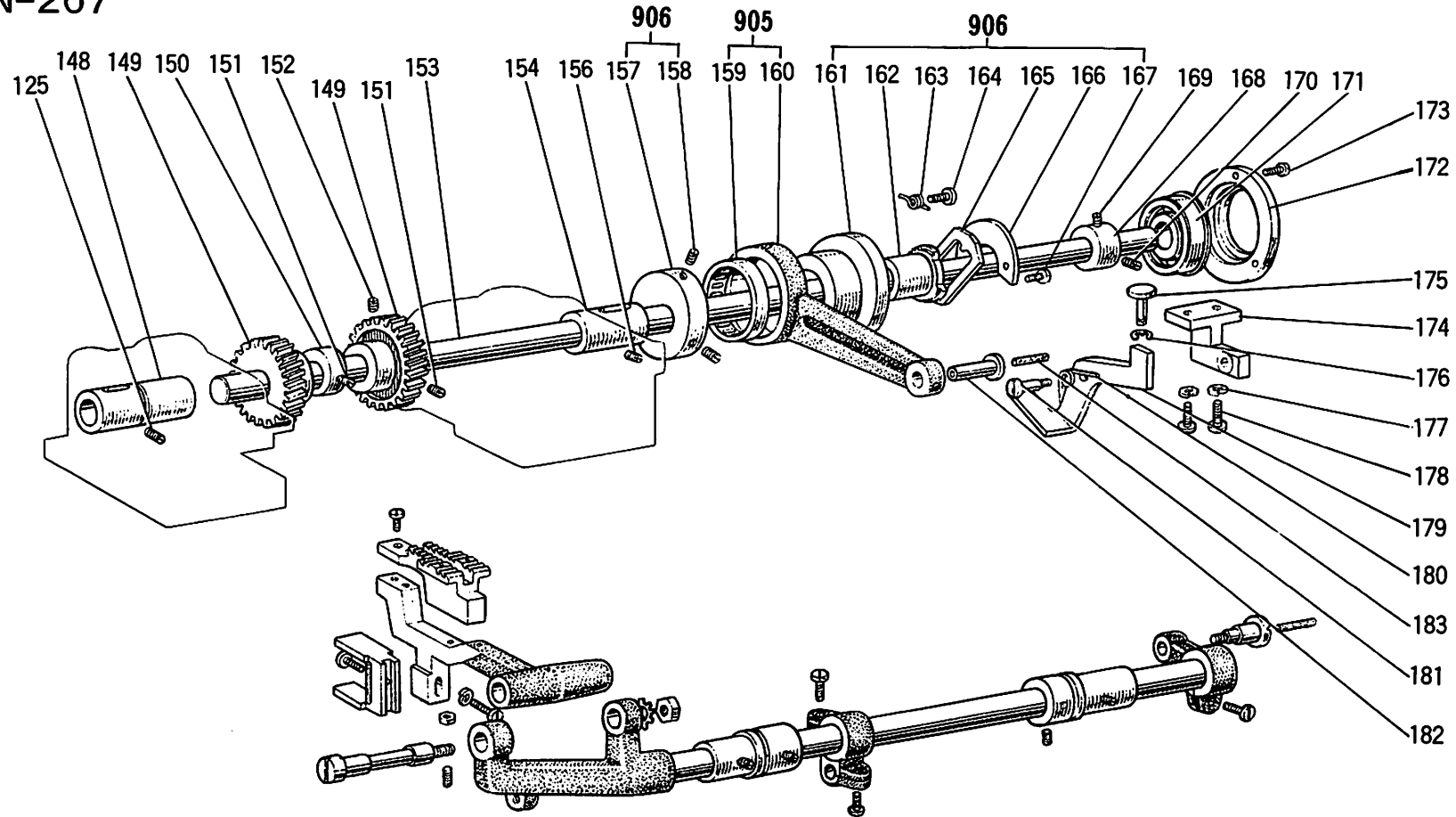

DN-260・262・265・267形 下軸部分 LOWER SHAFT MECHANISM

Fig. No.	サービス部品コード Part No.	資材コード Code No.	品 名	Name of Part	個 / 台 Amt. req				備 考 Remarks
					DN260	DN262	DN265	DN267	
148		W445890H01	メ タ ル (下軸左)	Hook driving shaft bushing (left)	①	①	①	①	
149		W319984H01	ネジハグルマ (大)	Gear (large)	②	②	②	②	
150		W445912H01	ヘンシンリン (送り上下カム)	Feed lifting cam	①	①	①	①	
151		W468269H01	トメネジボウサキ 1/4(40)×5.5	Screw	②	②	②	②	
152		W500036H01	トメネジ 1/4(40)×4	Screw	⑧	⑧	⑧	⑧	
153		W445889H01	シ タ ジ ク	Hook driving shaft	①	①	①	①	
154		W445891H01	メ タ ル (下軸右)	Hook driving shaft bushing (right)	①	①	①	①	
156		W501017H01	トメネジ 1/4(24)×13	Screw	②	②	②	②	
157		W450960H01	カ ラ ー	Collar	①	①	①	①	
158		B509060H01	トメネジ 15/64(28)×9	Screw	②	②	②	②	
159		W462946H01	ニードルベアリング NTNINA-SC208	Needle bearing	①	①	①	①	
160		W445906H01	レンセツカン (送りロッド)	Feed connection	①	①			
161		W453593H01	ヘンシンリン (駆動輪)	Eccentric link	①	①	①	①	
162		W453594H01	ヘンシンリン (偏心輪)	Eccentric	①	①	①	①	
163		W501163H01	ヒネリバネ	Spring	①	①	①	①	
164		W501162H01	ヒラネジダンツキ 9/64(40)	Screw	①	①	①	①	
165		W446370H01	クラッチバン	Friction plate	①	①	①	①	
166		W446371H01	カ バ ー	Cover plate	①	①	①	①	
167		W500791H01	ヒラネジ 9/64(40)×4.5	Screw	②	②	②	②	
168		W445887H01	ブッシュ (玉軸受)	Needle bar connecting stud	①	①	①	①	
169		W500036H01	トメネジ 1/4(40)×4	Screw	①	①	①	①	
170		W468269H01	トメネジボウサキ 1/4(40)×5.5	Screw	①	①	①	①	
171		W445886H01	ジクウケ (下軸)	Ball bearing (lower shaft)	①	①	①	①	
905			送りロッド (組)	Feed connection Assy,	①	①			
906			送り調節器 (組)	Feed regulator Assy,	①	①	①	①	
172		W461041H01	オサエイタ (玉軸受)	Bearing holder	①	①	①	①	
173		W500994H01	マルサラネジ 9/64(40)×7	Screw	③	③	③	③	
174		W453591H01	トリツケダイ	Lever bracket	①	①	①	①	
175		W460512H01	オシボタン	Push button	①	①	①	①	
176		S592411H05	Eガタトメワ5	Stop ring	①	①	①	①	
177		S561121H03	バネザガネ	Spring washer	②	②	②	②	
178		W500182H01	ヒラネジ 11/64(40)×15	Screw	②	②	②	②	
179		W461027H01	レバ ー (押しボタン)	Push button lever	①	①	①	①	
180		W502469H01	ヒネリバネ	Twisted spring	①	①	①	①	
181		W500205H01	ヒラネジダンツキ 11/64(40)	Screw	①	①	①	①	
182		W501015H01	ピ ン	Pin	①	①	①	①	
183		W500231H01	ヒ モ 3φ×25	Oil wick	①	①	①	①	

DN-260 送り軸部分 LOWER FEED MECHANISM

DN-262
DN-265
DN-267

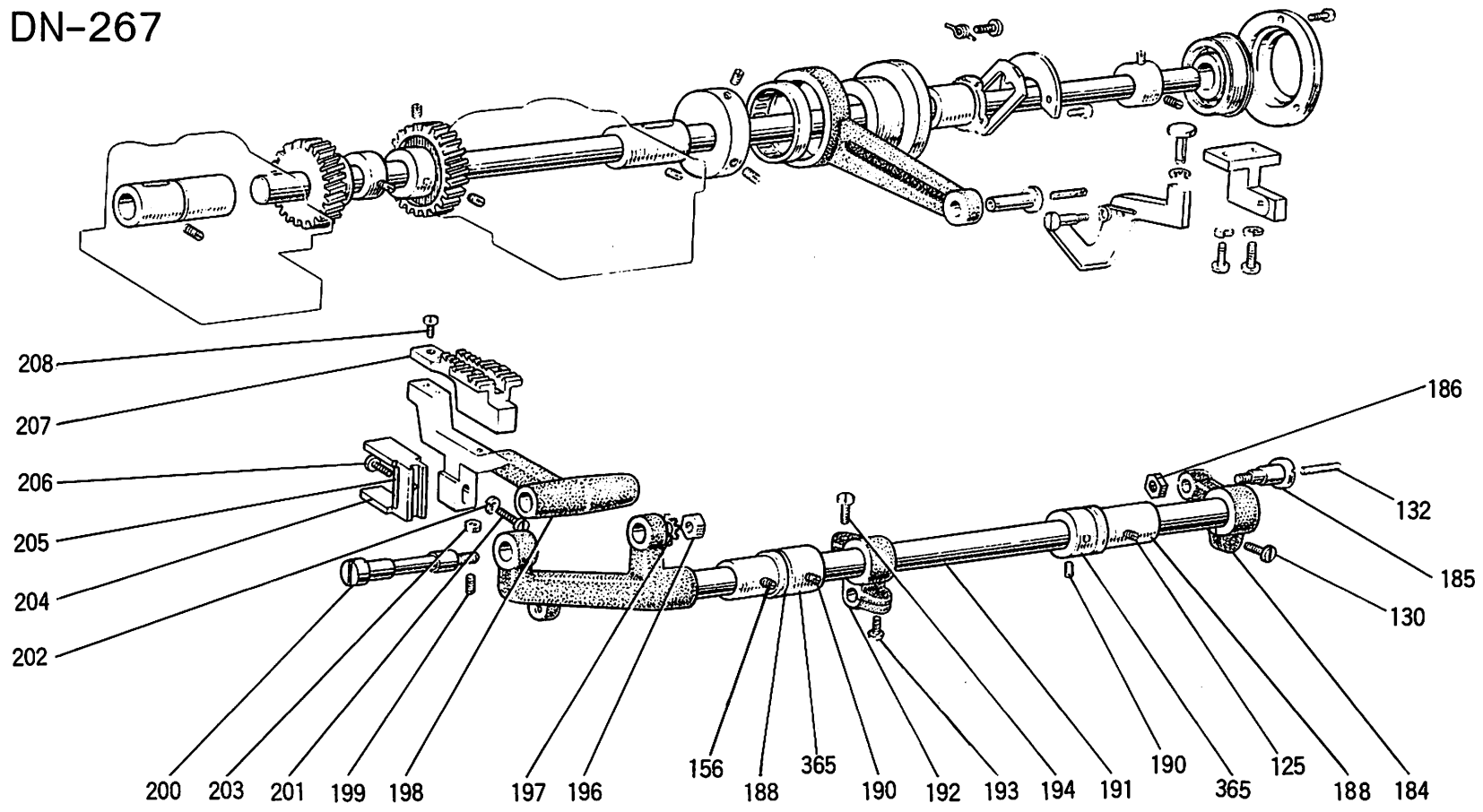

DN-260・262・265・267形 送り軸部分 LOWER FEED MECHANISM

Fig. No.	サービス部品コード Part No.	資材コード Code No.	品 名	Name of Part	個 / 台 Amt. req				備 考 Remarks
					DN260	DN262	DN265	DN267	
184		W445908H01	ウ デ (送り腕右)	Feed lifting crank(right)	①	①	①	①	
185		W501010H01	ヒラネジダンツキ 5/16(24)	Screw	①	①	①	①	
186		W501187H01	ナ ッ ト 5/16(24)	Nut	①	①	①	①	
188		W445910H01	メ タ ル (送り軸)	Feed driving rock shaft bushing	②	②	②	②	
190		B 508971 H01	ト メ ネ ジ 15/64(28)×4	Screw	④	④	④	④	
191		W319986H01	オ ク リ ジ ャ	Feed driving rock shaft	①	①	①	①	
192		W462949H01	ウ デ (送り腕左)	Feed driving crank(left)	①	①	①	①	
193		W501009H01	マルヒラネジ 1/4(24)×16	Screw	①	①	①	①	
194		B 509178 H01	ヒ ラ ネ ジ 3/16(28)×15	Screw	①	①	①	①	
196		W501058H01	ナ ッ ト 1/4(24)	Nut	①	①	①	①	
197		S 563122 H05	ハ ツ キ ザ ガ ネ B6	Washer	①	①	①	①	
198		W459348H01	オ ク リ ダ イ	Feed bar	①	①	①	①	
199		W501001H01	ト メ ネ ジ 1/8(40)×15	Screw	①	①	①	①	
200		W445911H01	マルヒラネジダンツキ (送り台支工軸)	Feed bar hinge stud	①	①	①	①	
201		W501002H01	マルヒラネジ 15/64(28)×13	Screw	①	①	①	①	
202		W500645H01	ザ ガ ネ	Washer	①	①	①	①	
203		W501210H01	ナ ッ ト 1/4(24)	Nut	①	①	①	①	
204		W445913H01	フ タ マ タ (送り台)	Feed eccentric fork	①	①	①	①	
205		W501011H01	フ ェ ル ト	Felt	①	①	①	①	
206		W501003H01	マルヒラネジ 1/8(44)×4	Screw	①	①	①	①	
207		W319988H01	オ ク リ	Feed dog	①		①		
		W467824H01	オ ク リ	Feed dog		①		①	
208		W501000H01	ヒ ラ ネ ジ 1/8(40)×7	Screw	②	②	②	②	
365		W445954H01	カ ラ ー	Collar	②	②	②	②	

カマ機構 HOOK MECHANISM

DN-260
DN-262
DN-265
DN-267

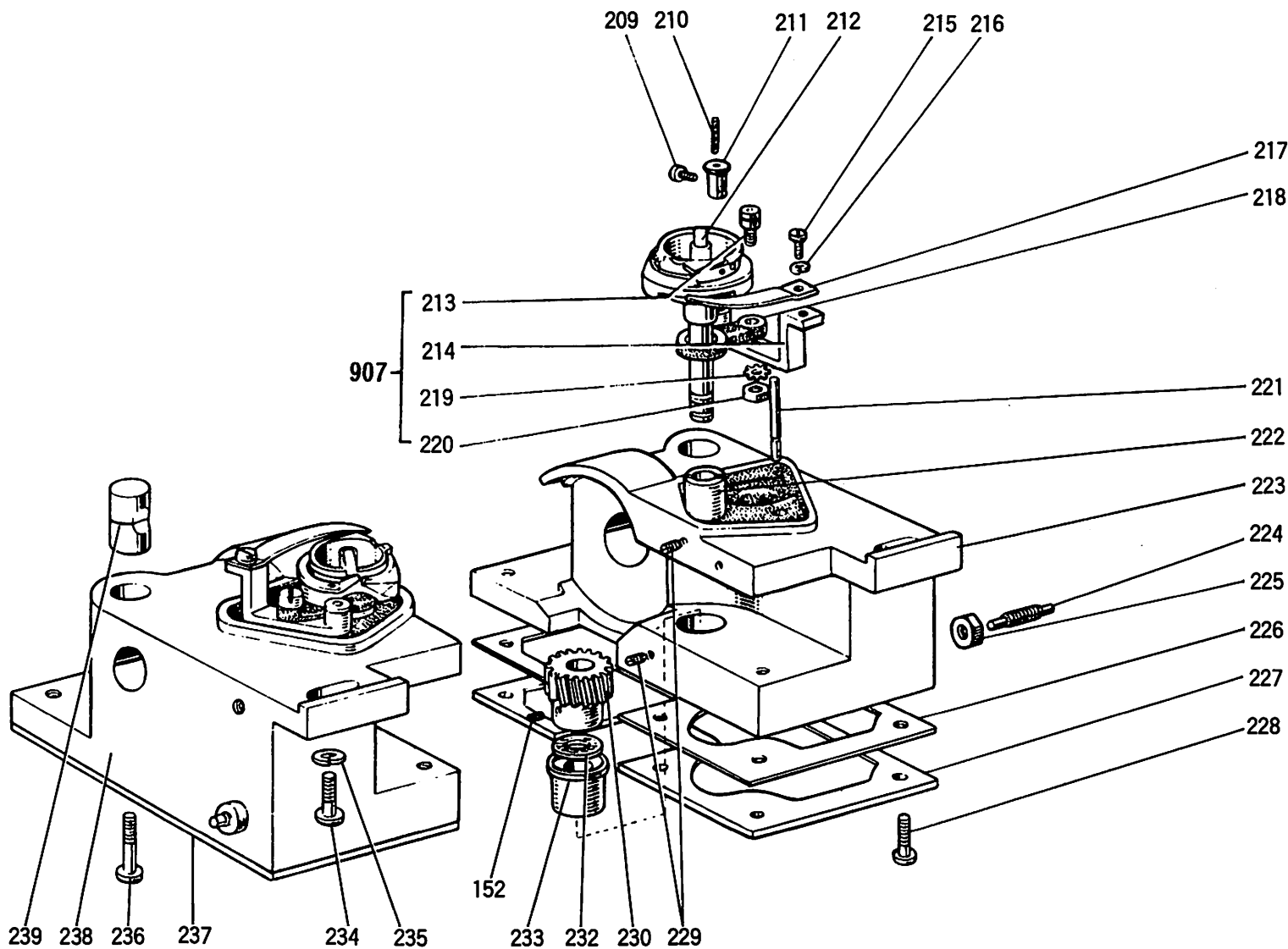

DN-260・262・265・267形 カマ機構 HOOK MECHANISM

Fig. No.	サービス部品コード Part No.	資材コード Code No.	品 名	Name of Part	個 / 台 Amt. req				備 考 Remarks
					DN260	DN262	DN265	DN267	
209		W469860H01	ヒ ラ ネ ジ 3/16(28)×22	Screw	②	②	②	②	
210		W462980H01	ヒ モ 2.5φ×15	Oil wick	②	②	②	②	
211		W444901H01	オープナーササエ (オープナささえ軸)	Opener supporter	②	②	②	②	
212		W319995H01	カ マ 12-15M	Rotating hook Assy,	②		②		
		W326230H01	カ マ 12-15MM	Rotating hook Assy,		②		②	
213		W445904H01	トクシュネジ (オープナ支えピン)	Bobbin case opener lever pin	②	②	②	②	
214		W445902H01	オープナササエ	Bobbin case opener lever	②		②		
		W459390H01	オープナササエ	Bobbin case opener lever		②		②	
215		B 509270H01	マルヒラネジ 15/64(28)×30	Screw	②	②	②	②	
216		B 508956H01	ザ ガ ネ	Washer	②	②	②	②	
217		W445903H01	オ ー プ ナ ー	Bobbin case opener	②	②	②	②	
218		W445900H01	レンセツカン (カマクランク腕)	Bobbin case opener lever link	②	②	②	②	
219		S 563122H04	ハツキザガネ B5	Toothed washer	②	②	②	②	
220		B 509177H01	ナ ッ ト 3/16(32)	Nut	②	②	②	②	
221		W502458H01	オイルゲージ	Oil gauge	②	②	②	②	
222		W445898H01	メ タ ル (カマ軸上)	Hook driving shaft bushing (upper)	②		②		
		W462940H01	メ タ ル (カマ軸上)	Hook driving shaft bushing (upper)		②		②	
223		W220612H01	カ マ ダ イ (右)	Hook saddle (right)	①		①		
		W220606H01	カ マ ダ イ (右)	Hook saddle (right)		①		①	
224		W502747H01	トクシュネジ (コックねじ)	Cock screw	②	②	②	②	
225		B 509177H01	ナ ッ ト 3/16(32)	Nut	②	②	②	②	
226		W445895H01	ガ ス ケ ッ ト	Gasket	②	②	②	②	
227		W445896H01	フ タ (カマ台左)	Oil cover (hook saddle left)	①	①	①	①	
228		W469526H01	ブラマイネジ 3/16(28)×11	Screw	①⑥	①⑥	①⑥	①⑥	
907			オープナーささえ (組)	Bobbin case opener Assy,	①		①		
			オープナーささえ (組)	Bobbin case opener Assy,		①		①	
229		B 508971H01	トメネジ 15/64(28)×4	Screw	④	④	④	④	
230		W445892H01	ネジハグルマ (小)	Cam shaft gear (small)	②	②	②	②	
232		W501041H01	ザ ガ ネ	Washer	②	②	②	②	
233		W445899H01	メ タ ル (カマ軸下)	Hook driving shaft bushing (lower)	②	②	②	②	
234		W501208H01	マルヒラネジ 1/4(24)×28	Screw	②	②	②	②	
235		B 509331H01	ザ ガ ネ	Washer	②	②	②	②	
236		B 509074H01	ヒ ラ ネ ジ 15/64(28)×30	Screw	②	②	②	②	
237		W445893H01	フ タ (カマ台右)	Oil cover	①	①	①	①	
238		W220611H01	カ マ ダ イ (左)	Hook saddle (left)	①		①		
		W220626H01	カ マ ダ イ (左)	Hook saddle (left)		①		①	
239		W445905H01	ブ ッ シ ュ	Pinching bushing	②	②	②	②	

給油機構部分 LUBRICATION MECHANISM

DN-260
DN-262
DN-265
DN-267

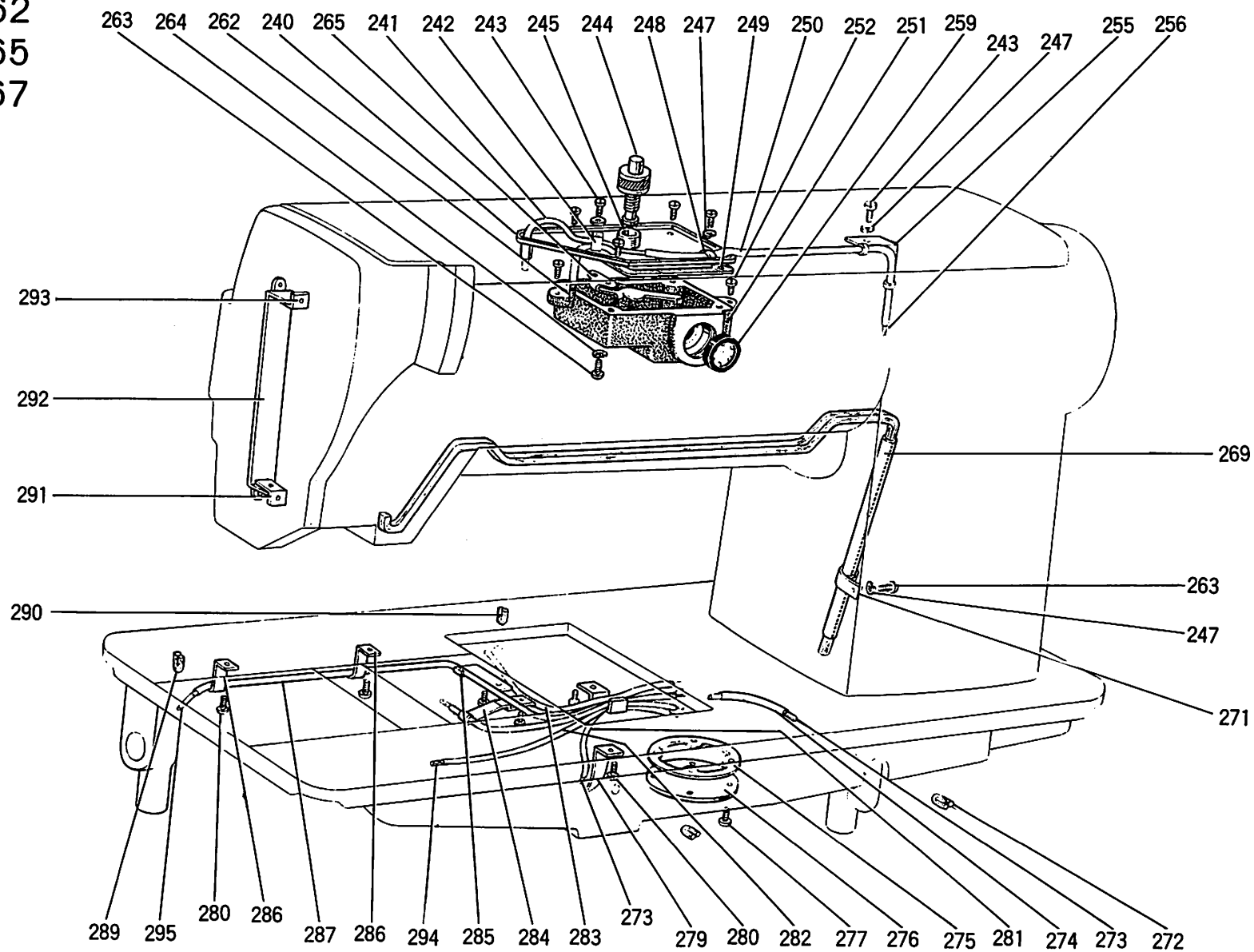
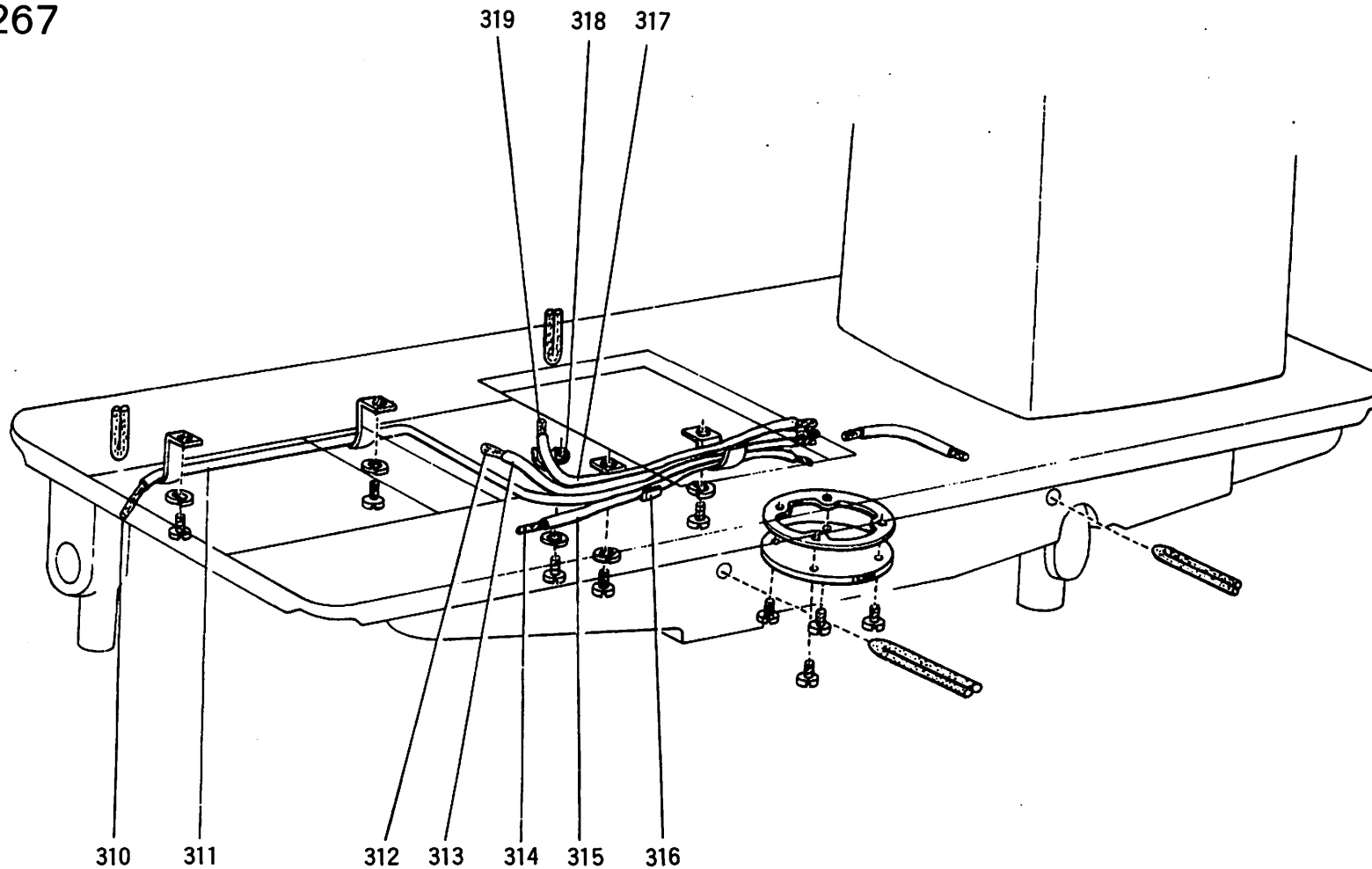

Fig. No.	サービス部品コード Part No.	資材コード Code No.	品 名	Name of Part	個 / 台 Amt. req.				備 考 Remarks
					DN260	DN262	DN265	DN267	
240		W319980H01	フ タ	Drip pan cover	①	①	①	①	
241		W444138H01	ひ も 2.5φ×240	Oil wick	①	①	①	①	
242		W501220H01	ホ ル ダ	Pipe holder	①	①	①	①	
243		B509065H01	ヒ ラ ネ ジ 9/64(40)×6.5	Screw	⑥	⑥	⑥	⑥	
244		W462955H01	ダ ー ナ	Oil plunger	①	①	①	①	
245		W502231H01	ブ ッ シ ュ	Bushing	①	①	①	①	
247		S561121H02	バ ネ ザ ガ ネ 3.5	Spring washer	⑧	⑧	⑧	⑧	
248		W444230H01	ホ ル ダ	Pipe holder	①	①	①	①	
249		W444116H01	ガ ス ケ ッ ト	Packing	①	①	①	①	
250		W462994H01	バ イ プ (ビニール管)	Vinyl pipe	①	①	①	①	
251		W444114H01	オ イ ル タ ン ク	Oil tank	①	①	①	①	
252		B509068H01	ヒ ラ ネ ジ 9/64(40)×10	Screw	②	②	②	②	
255		W444699H01	ホ ル ダ	Pipe holder	①	①	①	①	
256		W469530H01	ヒ モ 2.5φ×260	Oil wick	①	①	①	①	
259		W472784H01	ア ブ ラ マ ド	Oil flow indicator	①	①	①	①	
262		W462954H01	フ ェ ル ト	Felt	①	①	①	①	
263		B503897H01	ヒ ラ ネ ジ 1/8(44)×3.5	Screw	②	②	②	②	
264		S561121H01	バ ネ ザ ガ ネ 3	Spring washer	②	②	②	②	
265		W446556H01	イ タ バ ネ	Pipe holder	①	①	①	①	
269		W462995H01	バ イ プ (ビニール)	Vinyl pipe	①	①	①	①	
271		W501202H01	ホ ル ダ	Pipe holder	①	①	①	①	
272		W462983H01	ヒ モ 2.5φ×50	Oil wick	②	②	②	②	
273		W462984H01	ヒ モ	Oil wick	②	②			
274		W462996H01	バ イ プ (ビニール)	Vinyl pipe	②	②	②	②	
275		W444122H01	ガ ス ケ ッ ト	Packing	①	①	①	①	
276		W444237H01	フ タ	Cover	①	①	①	①	
277		W467868H01	ブ ラ マ イ ネ ジ 11/64(40)×13	Screw	④	④	④	④	
279		W551200H01	ホ ル ダ	Pipe holder	①	①	①	①	
280		W500791H01	ヒ ラ ネ ジ 9/64(40)×4.5	Screw	③	③	③	③	
281		W462997H01	バ イ プ (ビニール)	Vinyl pipe	①	①			
282		W462998H01	バ イ プ (ビニール)	Vinyl pipe	①	①			
283		W464001H01	バ イ プ (ビニール)	Vinyl pipe	①	①			
284		W453596H01	ホ ル ダ	Pipe holder	①	①	①	①	
285		W446254H01	ホ ル ダ	Pipe holder	①	①	①	①	
286		W446255H01	ホ ル ダ	Pipe holder	②	②	②	②	
287		W462999H01	バ イ プ (ビニール)	Vinyl pipe	①	①			
289		W462979H01	ヒ モ 2.5φ×80	Oil wick	①	①	①	①	
290		W462983H01	ヒ モ 2.5φ×50	Oil wick	①	①	①	①	
291		W445945H01	ホ ル ダ	Felt holder (2)	①	①	①	①	
292		W445875H01	フ ェ ル ト	Felt	①	①	①	①	
293		W445944H01	ホ ル ダ	Felt holder (1)	①	①	①	①	
294		W462985H01	ヒ モ 2.5φ×220	Oil wick	②	②			
295		W462986H01	ヒ モ 2.5φ×470	Oil wick	①	①			

給油機構部分 LUBRICATION MECHANISM

DN-265

DN-267



DN-265・267形 給油機構部分 LUBRICATION MECHANISM (FOR DN-265・267)

Fig. No.	サービス部品コード Part No.	資材コード Code No.	品 名	Name of part	個 / 台 Amt. req				備 考 Remarks
					DN260	DN262	DN265	DN267	
310		W462989 H01	ヒモ (DN265) 2.5φ×620	Oil wick			①		
		W462990 H01	ヒモ (DN267) 2.5φ×640	Oil wick				①	
311		W464003 H01	パイプ(ビニール) (DN265)	Vinyl pipe			①		
		W464004 H01	パイプ(ビニール) (DN267)	Vinyl pipe				①	
312		W462988 H01	ヒモ (DN265,267) 2.5φ×300	Oil wick			①	①	
313		W464002 H01	パイプ(ビニール) (DN265,267)	Vinyl pipe			①	①	
314		W444138 H01	ヒモ (DN265,257) 2.5φ×240	Oil wick			①	①	
315		W464051 H01	パイプ(ビニール) (DN265,267)	Vinyl pipe			①	①	
316		W501201 H01	ホルダ (DN265,267)	Pipe holder			①	①	
317		W464006 H01	パイプ(ビニール) (φ φ)	Vinyl pipe			①	①	
318		W444230 H01	ホルダ (DN265,267)	Pipe holder			②	②	
319		W462992 H01	ヒモ (DN265,267) 2.5φ×320	Oil wick			①	①	

返し縫い機構部分 REVERSE LEVER MECHANISM

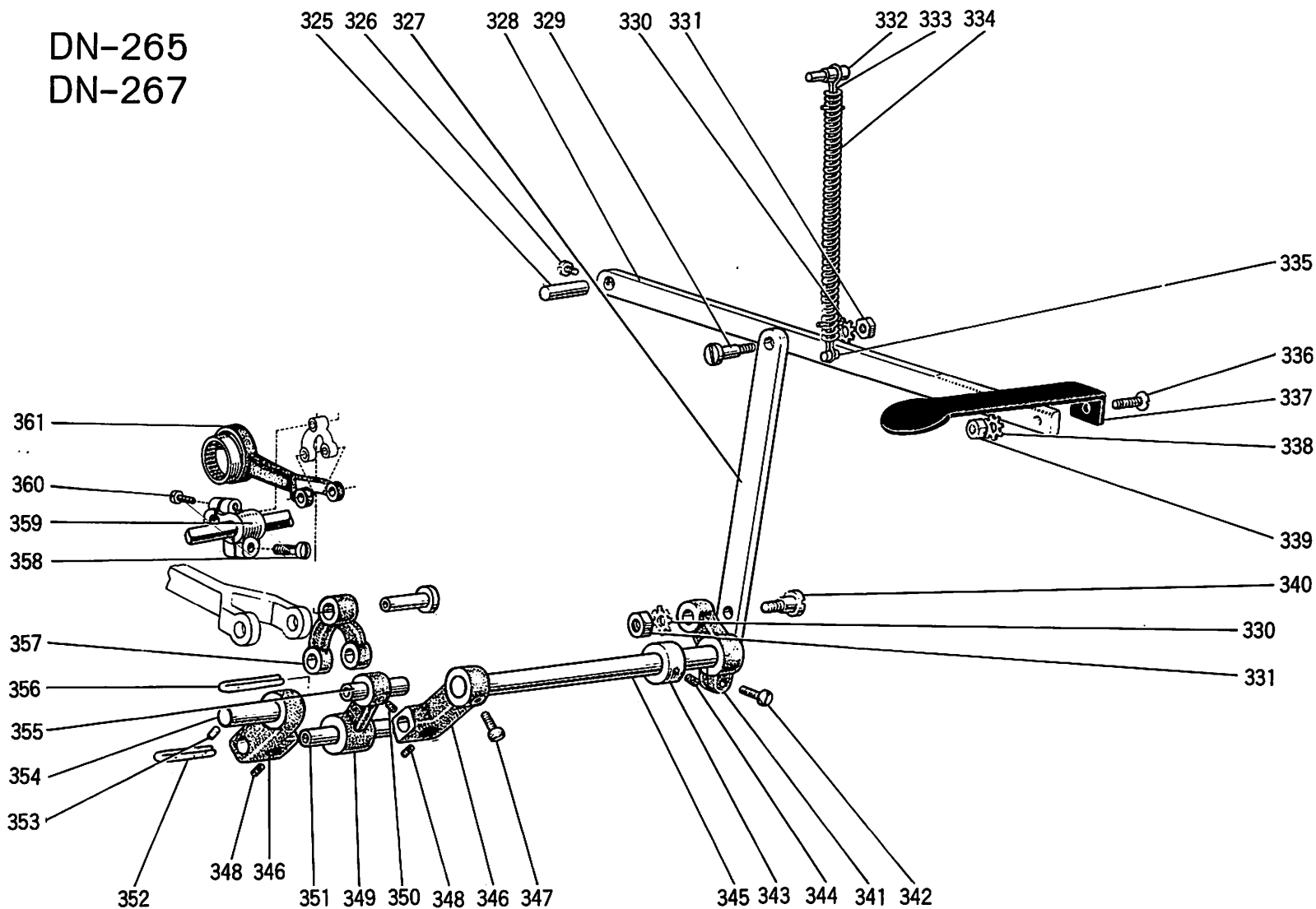

DN-265・267形 返し縫い機構部分 REVERSE LEVER MECHANISM (FOR DN-265・267)

Fig. No.	サービス部品コード Part No.	資材コード Code No.	品 名	Name of Part	個 / 台 Amt. req				備 考 Remarks
					DN260	DN262	DN265	DN267	
325		W502791H01	ジ ク	Pin			①	①	
326		B 509065H01	平 ね じ 9/64(40)×6.5	Screw			①	①	
327		W462951H01	リンク (連結板)	Reverse lever connecting plate			①	①	
328		W459354H01	レバー (返し縫てこ)	Reverse stitch lever			①	①	
329		W501246H01	ヒラネジ ダンツキ	Hinge screw			①	①	
330		S 563122H05	ハツキザガネ B6	Lock washer			②	②	
331		W501883H01	ナ ッ ト 15/64(28)	Nut			②	②	
332		W502343H01	ダンツキピン	Spring guide pin			①	①	
333		W502928H01	カ ケ ガ ネ	Hook for spring			②	②	
334		W461028H01	ツルマキバネ	Coil spring			①	①	
335		W502032H01	トクシュネジ (ばね掛けピン)	Pin for spring			①	①	
336		W501934H01	サラネジ 3/16(28)×10	Screw			①	①	
337		W459355H01	オ サ エ イ タ	Reverse stitch plate			①	①	
338		S 563122H04	ハツキザガネ B5	Lock washer			①	①	
339		W500001H01	ナ ッ ト 3/16(28)	Nut			①	①	
340		W501570H01	マルヒラネジ ダンツキ	Hinge screw			①	①	
341		W502924H01	ウデ (返し縫右)	Reverse stitch shaft crank(right)			①	①	
342		B 503844H01	ヒラネジ 11/64(40)×13	Screw			①	①	
343		W446142H01	カ ラ ー	Collar			①	①	
344		B 509087H01	トメネジ 15/64(28)×6	Screw			②	②	
345		W462952H01	ジク (返し縫)	Reverse stitch shaft			①	①	
346		W461018H01	ウデ (返し縫左)	Reverse stitch shaft crank(left)			②	②	
347		B 509256H01	マルヒラネジボウサキ15/64(28)	Screw			①	①	
348		B 509266H01	トメネジ 11/64(40)×4	Screw			②	②	
349		W460582H01	レンセツカン (揺動腕)	Bell crank			①	①	
350		W500151H01	トメネジ 3/16(28)×5	Screw			①	①	
351		W460583H01	ジ ク	Pin			①	①	
352		W462729H01	ヒ モ 2.5φ×125	Oil wick			①	①	
353		W500478H01	トメネジ 1/4(24)×7	Screw			①	①	
354		W461020H01	ジ ク	Pin			①	①	
355		W502921H01	ゲンツキジク	Pin			①	①	
356		W462981H01	ヒ モ 2.5φ×60	Oil wick			①	①	
357		W460584H01	レンセツカン	Link			①	①	
358		W501009H01	マルヒラネジ 1/4(24)×16	Screw			①	①	
359		W462947H01	ウ デ (送り腕左)	Feed arm(left)			①	①	
360		B 509178H01	ヒラネジ 3/16(28)×15	Screw			①	①	
361		W460585H01	レンセツカン (送りロッド)	Feed connecting rod Assy,			①	①	

ゲージ部品 GAUGE PARTS

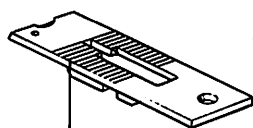

Fig. No	ゲージ巾
62	3/8
	1/2
	3/4
	7/8

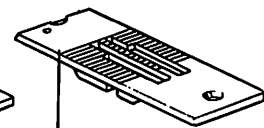

Fig. No	ゲージ巾
62	3/8
	1/2
	3/4
	7/8

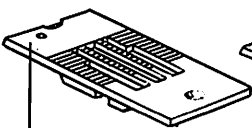

Fig. No	ゲージ巾
62	1/2
	3/4
	7/8

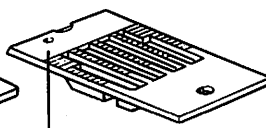

Fig. No	ゲージ巾
62	1
	1 1/4
	1 1/2
	1 3/4

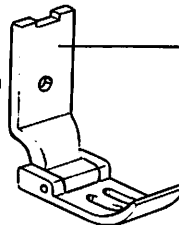

Fig. No	ゲージ巾
103	3/8
	1/2
	3/4
	7/8
	1
	1 1/4
	1 1/2



Fig. No	ゲージ巾
139	3/8
	1/2
	3/4
	7/8
	1
	1 1/4

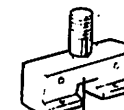

Fig. No	ゲージ巾
139	3/8
	1
	1 1/4
	1 1/2
	1 3/4

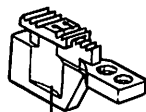

Fig. No	ゲージ巾
207	3/8
	1/2
	3/4

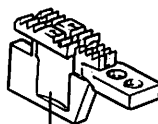

Fig. No	ゲージ巾
207	3/8
	1/2
	3/4
	7/8
	1

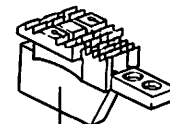

Fig. No	ゲージ巾
207	1/2
	3/4
	7/8

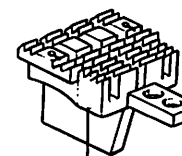
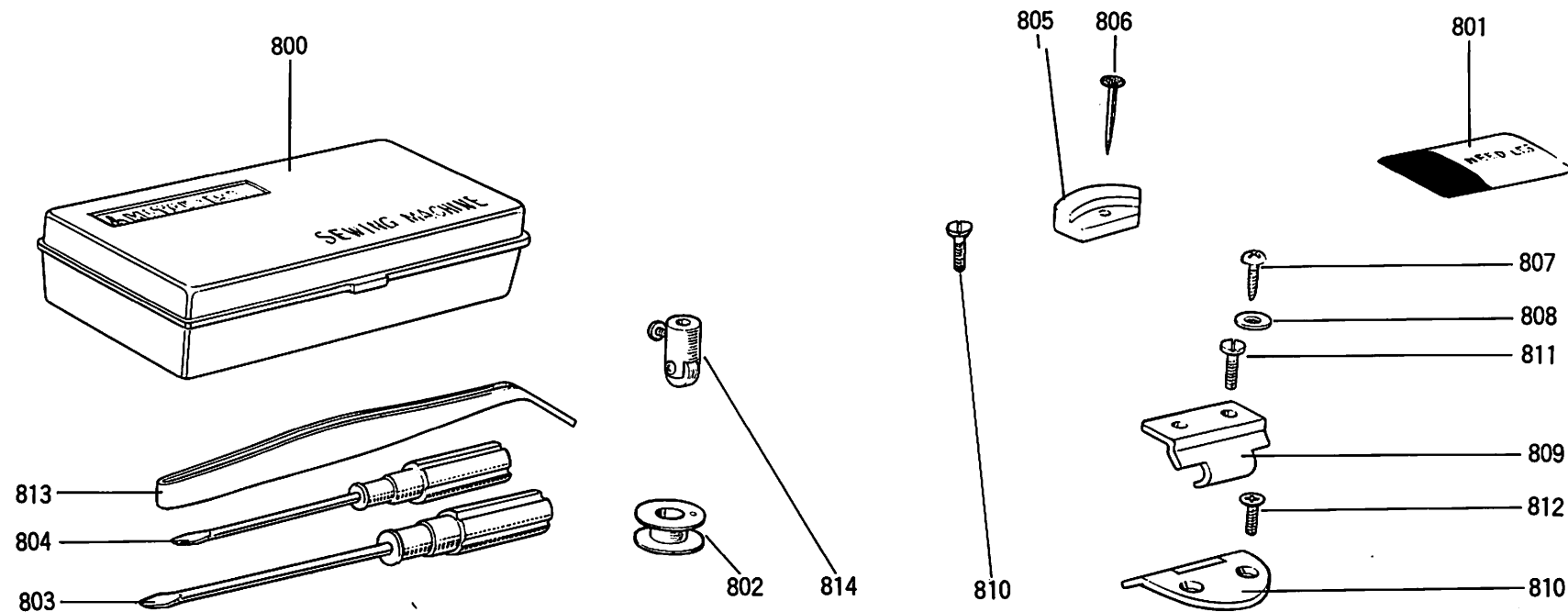

Fig. No	ゲージ巾
207	1
	1 1/4
	1 1/2
	1 3/4

ゲージ巾 Gauge size	Fig.No. 62	Fig.No. 103	Fig.No. 139	Fig.No. 207
	針板 Needle plate	押工 Presser foot	針ダキ Needle clamp	送り Feed dog
3/8	W467275 H01	W328859 H01	W467852 H01	W467288 H01
1/2	W467276 H01	W328860 H01	W467853 H01	W467289 H01
3/4	W467277 H01	W328861 H01	W467854 H01	W467290 H01
7/8	W467274 H01	W328858 H01	W467851 H01	W467287 H01
1	W467278 H01	W328862 H01	W467855 H01	W467291 H01
1 1/4	W467279 H01	W328863 H01	W467856 H01	W467292 H01
1 1/2	W467280 H01	W328864 H01	W467857 H01	W467293 H01
1 3/4	W467281 H01	W328865 H01	W467858 H01	W467294 H01
2	W467282 H01	W328866 H01	W467859 H01	W467295 H01
2 1/4	W467283 H01	W328867 H01	W467860 H01	W467296 H01
2 1/2	W467818 H01	W328874 H01	W467816 H01	W467820 H01
1	W467284 H01	W328868 H01	W467861 H01	W467297 H01
1 1/4	W467285 H01	W328869 H01	W467862 H01	W467298 H01
1 1/2	W467819 H01	W328875 H01	W467817 H01	W467821 H01
1 3/4	W467286 H01	W328870 H01	W467863 H01	W467299 H01

付属品 (付属品箱) ACCESSORIES (ACCESSORIES BOX)

Fig. No.	サービス部品コード Part No.	資材コード Code No.	品 名	Name of Part	個 / 台 Amt. req				備 考 Remarks
					DN260	DN262	DN265	DN267	
800		W450684H0	付 属 品 箱	Accessories box	①	①	①	①	
801		S 970004H02	ハ リ DP×5 #14	Needle	⑩		⑩		
		S 970004H06	ハ リ DP×5 #21	Needle		⑩		⑩	
802		W455964H01	ボ ビ ン	Bobbin	④		④		
		W462929H01	ボ ビ ン	Bobbin		④		④	
803		W443654H01	ネ ジ 回 し (中)	Screw driver (middle)	①	①	①	①	
804		W443655H01	ネ ジ 回 し (小)	Screw driver (small)	①	①	①	①	
805		W449461H01	防 振 ゴ ム	Vibration preventing	④	④	④	④	
806			釘 (8分釘)	Nail	⑨	⑨	⑨	⑨	
807		S 519132H01	丸 木 ネ ジ 4.5×20	Screw	②	②	②	②	
808		S 562111H01	座 金 M6	Washer	②	②	②	②	
809		W445507H01	蝶 番 (1)	Hinge hook (1)	②	②	②	②	
810		W445508H01	蝶 番 (2)	Hinge hook (2)	②	②	②	②	
811		W461766H01	丸 平 ネ ジ	Screw	④	④	④	④	
812		S 519131H01	皿 木 ネ ジ 5.5×25	Screw	⑧	⑧	⑧	⑧	
813		W445350H01	ピンセット	Tweezer	①	①	①	①	
814		W462918H01	ローラーダキ (組)	Roller (set)	①	①	①	①	
815		W502167H01	丸 平 ネ ジ	Screw	②	②	②	②	



付属品 ACCESSORIES

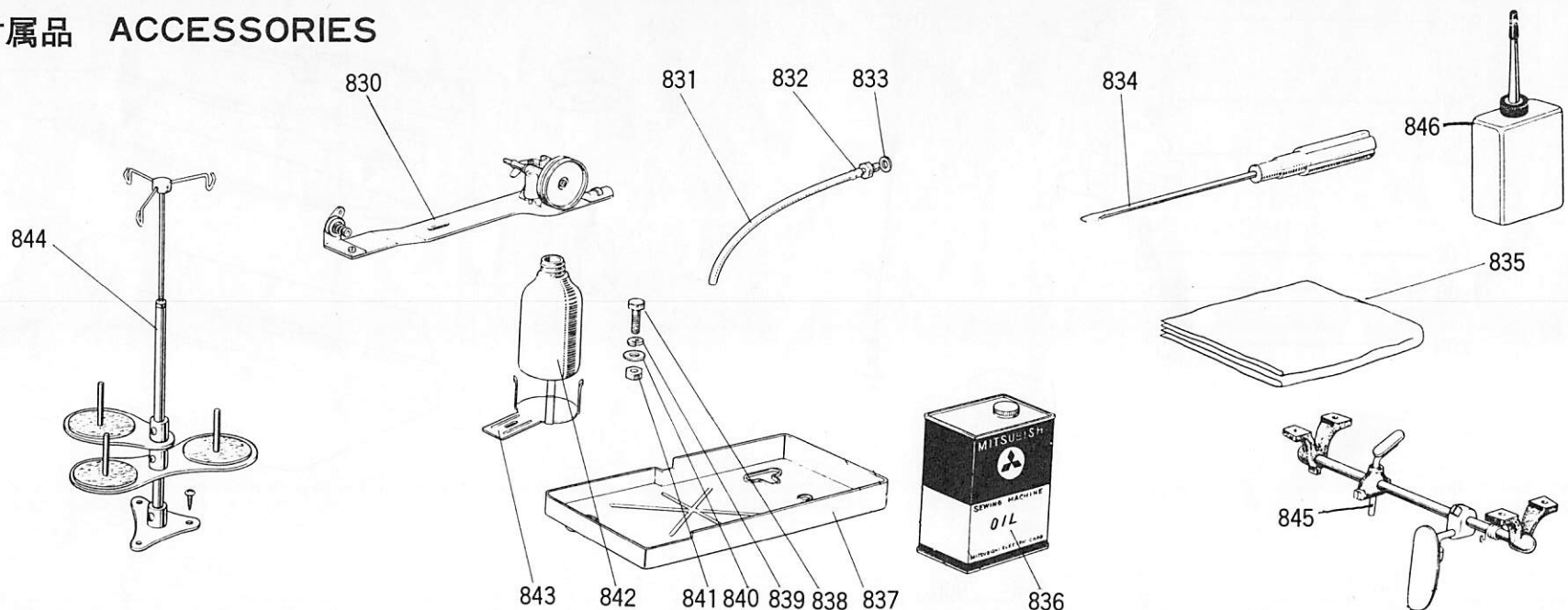

Fig. No.	サービス部品コード Part No.	資材コード Code No.	品名	Name of Part	個/台 Amt. req				備考 Remarks
					DN260	DN262	DN265	DN267	
830		SM31097G01 SM31292G01	糸巻仕掛 糸巻仕掛	Bobbin winder Assy, Bobbin winder Assy,	①		①	①	
831		W451152H01	ビニール管	Vinyl pipe	①	①	①	①	
832		W446050H01	ネジブッシュ	Screw bushing	①	①	①	①	
833		W500812H01	パッキング	Packing	①	①	①	①	
834		W330196H01	ネジ回し(大)	Screw driver (large)	①	①	①	①	
835		W220627H01	ビニールカバー	Vinyl cover	①	①	①	①	
836		W219663H01	油缶	Oil can	①	①	①	①	
837		W220638H01	油受け	Oil pan	①	①	①	①	
838		W990013H01	ボルト	Bolt	①	①	①	①	
839		W990014H01	バネ座金	Spring washer	①	①	①	①	
840		W502735H01	座金	Washer	①	①	①	①	
841		W990015H01	ナット	Nut	①	①	①	①	
842		W319422H01	油ビン	Oil bottle	①	①	①	①	
843		W453513H01	油受け台	Oil bottle holder	①	①	①	①	
844		W218874H01	糸立仕掛	Cotton stud assembly	①	①	①	①	
845		SM31048H01	ヒザ上げ仕掛	Knee lifter (set)	①	①	①	①	
846			油差し(大)	Oiler (large)	①	①	①	①	

MEMO

MEMO

三菱電機



未来を開発する